



TUFHZ Series

LED Exit Sign for Hazardous Locations:
 Class I Zone 2 Groups: IIA, IIB and IIC
 Class I Division 2 Groups: A, B, C and D

Project/Location: _____

Contractor: _____

Date: _____

Prepared by: _____

Features

- Certified Class I Zone 2, Groups IIA, IIB and IIC
- Certified Class I Division 2, Groups A, B, C and D as per CSA C22.2 No.137-M1981
- Temperature Code: T6 (maximum 85°C as per Canadian Electrical Code, Part I and CSA C22.2 No.137-M1981)
- CSA certified, meets or exceeds C860 requirements
- Input voltages: 120 to 347Vac universal AC-input; 6 to 48Vdc universal DC-input
- High impact thermoplastic frame, with built-in gasket to prevent water infiltration
- Suited for areas with the risk of presence of flammable gases, vapors or liquids able to create an explosive atmosphere
- Sealed faceplate of heavy-duty, vandal-resistant polycarbonate
- Tamper-resistant, hermetically sealed magnetic test switch
- Self-diagnostic circuitry is standard on self-powered models
- Sealed, maintenance-free, Nickel-Cadmium batteries
- Batteries recharge as per CSA requirements and provide 90 minutes of emergency operation
- Long-life, energy-efficient **AlInGaP** red LED light source
- Energy efficient – consumes less than 3watts in AC or DC mode



Typical Specification

Supply and install Ready-Lite **TUFHZ Series** LED exit signs. The equipment shall operate with universal two-wire AC input voltage from 120Vac to 347Vac at less than 3watts and universal two-wire DC input voltage from 6Vdc to 48Vdc at less than 2watts for single and double face signs. Designed specifically for hazardous locations, the equipment frame shall be of industrial grade high impact thermoplastic with a gasket around lenses and canopy. The faceplate(s) shall be constructed of heavy-duty vandal-resistant polycarbonate and feature an even illuminated legend. The light source shall be light emitting diodes (LED). Red LED technology shall be **AlInGaP**. An LED-sensitive diffuser shall be mounted behind the legend to provide the 6" high by 3/4" stroke letters with even illumination.

The equipment shall be certified for Hazardous Locations; Class I Zone 2 Groups: IIA, IIB and IIC and Class I Division 2 Groups: A, B, C and D with a temperature code T6 (Maximum 85°C). The equipment shall be designed specifically for high abuse areas. The self-powered model shall stay illuminated during emergency operation for at least 90 minutes upon AC failure and shall include a magnetic test switch and self-testing/self-diagnostic functions.

The equipment shall automatically self test for 5 minutes every 30 days, 30 minutes every 60 days and 90 minutes annually. A "Service required" lamp shall be located near the test switch and flash when a fault is detected. A two-LED diagnostic display shall be located inside the equipment and shall identify the eventual source of failure (battery, charger circuitry, or LED lamps).

The exit sign shall be CSA-C860 approved.

The combination unit shall be Ready-Lite model: _____.

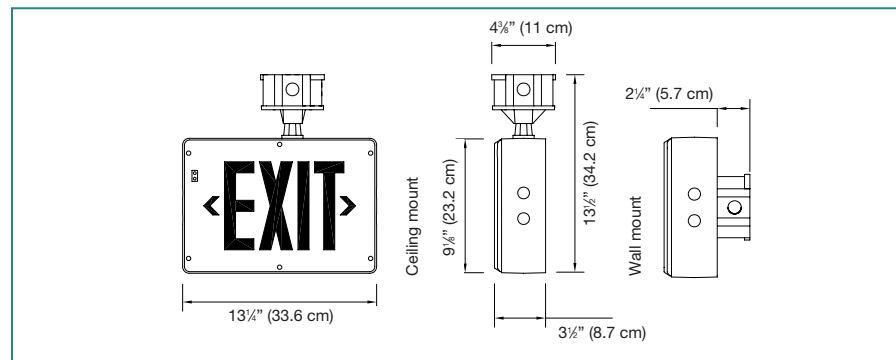

Power Consumption

Model Number	AC Specs	DC Specs	
AC/DC, red	120 / 347Vac	6 to 48Vdc	Less than 2W
AC/DC, green	120 / 347Vac	6 to 48Vdc	Less than 2W
Self-powered, red	120 / 347Vac	NiCad battery	Min. 90 minutes
Self-powered, green	120 / 347Vac	NiCad battery	Min. 90 minutes
120Vac/Vdc 2 wires, red	120Vac	120Vdc	Less than 3W

Wire Guards

460.0080-RL	Wall Mount
-------------	------------

Ordering Information

Series	Faces	AC Voltage	Housing/Faceplate Colour	Voltage	Options
TUFHZ= Class I Zone 2 Exit	-1= single face, ceiling/Wall mount -2= double face, ceiling mount only	Blank= 120vac (with L120-2W only) -U= universal 120-347vac	GG= grey/grey	-DC= 6-48vdc -SPD= 120-347vac, self-powered (120 Min) c/w self-diagnostics (non-audible) -L120-2W= 120vac, 120vdc 2 wire (with blank A.C. only) -NEX= self-powered, NEXUS® System interface* *Consult your sales representative for options available with NEXUS® System.	Blank= red letters G= green letters

EXAMPLE: TUFHZ-2-UGG-DC

