



# LDX Series

## 6, 12 and 24 Volts Steel Battery Units

Project/Location: \_\_\_\_\_

Contractor: \_\_\_\_\_

Date: \_\_\_\_\_

Prepared by: \_\_\_\_\_

### Features

- Rugged steel cabinet with corrosion-resistant undercoating
- Removable front panel on cabinet provides easy access and allows unit to be mounted at ceiling height
- Unit comes standard with electronic lockout and brownout circuits
- Sealed dust-proof transfer relay, test switch and LED indicator lights
- Solid-state pulse-type charger – current-limited, temperature-compensated, short-circuit proof and reverse-polarity protected.
- Long-life, maintenance-free lead acid battery
- NEXUS® compatible



### Typical Specification

Supply and install a complete emergency lighting system as described herein and shown on the drawings.

The Ready-Lite Smart Diagnostic micro-controller board shall supply the rated load for a minimum of a 1/2 hour to 87.5% of the rated battery voltage. The unit shall be rated 120V or 347V, 60 Hz and be CSA listed.

The charger shall be fully computer tested and its charge voltage factory set to  $\pm 1\%$  tolerance. Chargers with field-adjusted potentiometers are not acceptable. A pulse-type charger shall be employed to promote long battery life and reduce the potential for grid corrosion. The charger shall provide a continuous high charge to recharge the battery, when the battery is at full capacity, the charger will shut-off. Periodically the charger shall provide a pulse of energy to keep the battery topped off. The pulse charger shall be current limited and precisely regulated by a micro-controller circuit, which samples the battery in relation to its temperature, state of charge and input voltage fluctuations. The charger shall be current limited, temperature compensated, short-circuit proof and reverse polarity protected. The unit shall be furnished with an electronic lockout circuit, which will connect the battery when the AC circuit is activated, and an electronic brownout circuit, which will activate the emergency lights when utility power dips below 75% of nominal voltage. A low voltage battery protection circuit shall be provided and will disconnect the load and circuitry from the fused output circuit when the battery reaches the end of discharge. The unit shall self-test for 1 minute every 30 days, 10 minutes on the 6th month and 30 minutes every 12 months. The unit shall be capable of full recharge in compliance with CSA specifications. The unit shall be furnished with sealed dust tight relay, a test switch and diagnostic LED indicator lights to continuously monitor the status of the unit: Battery Failure, Battery Disconnected, Charger Failure, Lamp Failure, Service Alarm, AC "ON", Charger High Rate. The unit shall come complete with tool-less emergency lighting heads requiring no tools to adjust or aim.

The unit shall be Ready-Lite model: \_\_\_\_\_.

### Wire Guards

460.0078-RL	Wall Mount - "A" Cabinet
460.0081-RL	Wall Mount - "B" Cabinet
460.0034-RL	Wall Mount - "C" Cabinet

### Power Consumption and Unit Rating

Model Number	AC Specs	Emergency power available for lamps					
		30min	1h00	1h30	2h00	4h00	
LDX636	120 / 347Vac	0.10 / 0.04 Amp	36	21	15	12	6
LDX672		0.22 / 0.08 Amp	72	42	30	24	12
LDX6108		0.22 / 0.08 Amp	108	63	45	36	18
LDX6180		0.22 / 0.08 Amp	180	105	75	60	30
LDX1236		0.09 / 0.03 Amp	36	21	5	2	6
LDX1272		0.15 / 0.06 Amp	72	42	30	24	12
LDX12100		0.34 / 0.12 Amp	100	58	42	33	17
LDX12144		0.40 / 0.14 Amp	144	84	60	48	24
LDX12216		0.41 / 0.14 Amp	216	117	83	67	33
LDX12250		0.41 / 0.14 Amp	250	144	100	83	42
LDX12360		0.43 / 0.15 Amp	360	210	150	120	60
LDX24144		0.55 / 0.20 Amp	144	84	60	48	24
LDX24200		0.67 / 0.23 Amp	200	117	83	67	33
LDX24288		0.67 / 0.23 Amp	288	168	120	96	48
LDX24350		0.67 / 0.23 Amp	350	200	144	120	60
LDX24432		0.67 / 0.23 Amp	432	250	180	144	72
LDX24550	0.88 / 0.33 Amp	550	320	230	180	90	
LDX24720	0.88 / 0.33 Amp	720	420	300	240	120	

Project/Location:

Contractor:

Date:

Prepared by:

# LDX Series

6, 12 and 24 Volts  
Steel Battery Units



## Dimensions

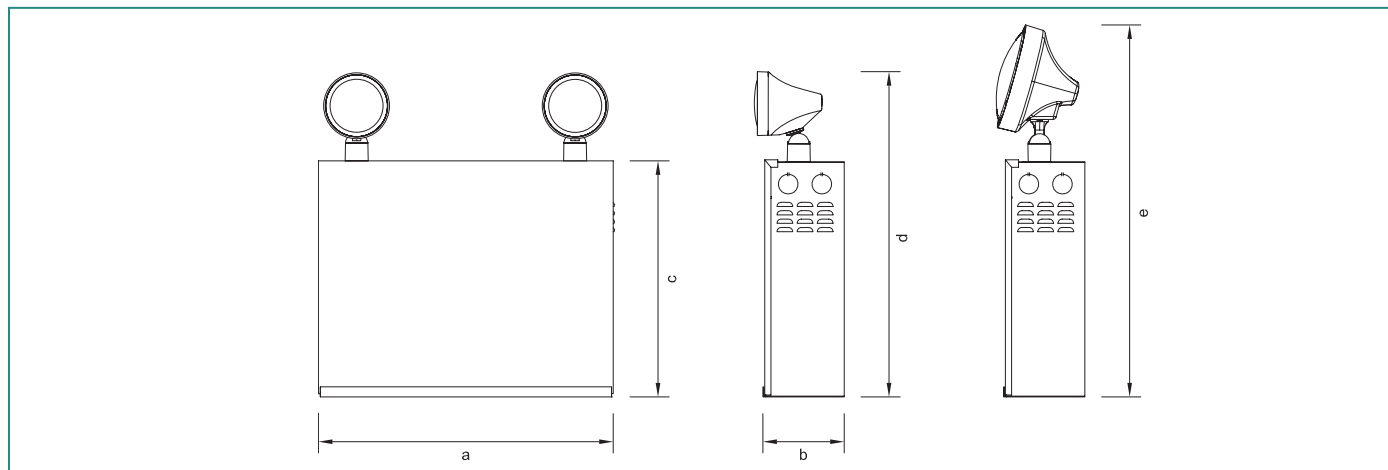

## Dimensions

Cabinet	Dimensions				
	a	b	c	d	e
A	13 3/4 in. [33.4 cm]	3 3/8 in. [9.2 cm]	10 1/2 in. [26.8 cm]	14 1/4 in. [36.8 cm]	16 1/2 in. [42.2 cm]
B	16 1/2 in. [41.0 cm]	5 1/2 in. [13.8 cm]	10 1/4 in. [26.1 cm]	14 1/4 in. [36.1 cm]	16 1/4 in. [41.4 cm]
C	23 3/4 in. [58.8 cm]	5 1/2 in. [13.8 cm]	10 1/4 in. [26.1 cm]	14 1/4 in. [36.1 cm]	16 1/4 in. [41.4 cm]

## Replacement Lamps

Ordering Code	Lamp Type	Voltage-Wattage
570.0016-RL	Mini tungsten (MT9W)	6V - 9W
570.0025-RL		12V - 9W
570.0045-RL		24V - 9W

For the complete list please refer to the Lamp Chart on page 113

## Ordering Information

Series	Capacity and Cabinet Size	Special Options	Number of Heads	Head Style / Lamp Wattage	Colour	AC Voltage	Options
<b>LDX6</b> = 6 volts  <b>EXAMPLE:</b> LDX6-108AD2RT9	<b>-36</b> = 72 watts [A]* <b>-72</b> = 72 watts [A]* <b>-108</b> = 108 watts [A]* <b>-180</b> = 180 watts [B]*	<b>Blank</b> = standard <b>AD</b> = self-diagnostic <b>ADN</b> = self-diagnostic non-audible <b>NEX</b> = NEXUS® system interface* (6 and 12 volts only)	<b>Blank</b> = no head <b>1</b> = one head <b>2</b> = two heads <b>3</b> = three heads	<b>RT9</b> = mini tungsten, 6V, 12V, 24V - 9 watts, wedge base <b>RT18</b> = mini tungsten, 12V - 18 watts, wedge base <b>RQ8</b> = mini halogen, 6V, 12V - 8 watts, quartz bi-pin <b>RQ12</b> = mini halogen, 6V, 12V, 24V - 12 watts, quartz bi-pin <b>RM6</b> = mini halogen, 6V - 6 watts, MR16 <b>RM10</b> = mini halogen, 6V - 10 watts, MR16 <b>RM12</b> = mini halogen, 12V, 24V - 12 watts, MR16 <b>RM20</b> = mini halogen, 12V, 24V - 20 watts, MR16 <b>LT9</b> = large tungsten, 6V, 12V, 24V - 9 watts, wedge base <b>LT18</b> = large tungsten, 12V, 24V - 18 watts, wedge base <b>LT25</b> = large tungsten, 6V, 12V, 24V - 25 watts, DCB <b>LQ8</b> = large halogen, 6V, 12V - 8 watts, quartz bi-pin <b>LQ12</b> = large halogen, 6V, 12V, 24V - 12 watts, quartz bi-pin <b>LQ20</b> = large halogen, 6V, 12V, 24V - 20watts, quartz bi-pin <b>LQ55</b> = large halogen, 12V - 55 watts, H3 <b>LQ70</b> = large halogen, 24V - 70 watts, H3 <b>LS9</b> = large tungsten, 6V - 9 watts, sealed beam <b>LS18</b> = large tungsten, 6V, 12V - 18 watts, sealed beam <b>LS25</b> = large tungsten, 6V, 12V, - 25 watts, sealed beam <b>LH8</b> = large halogen, 6V, 12V - 8 watts, quartz sealed beam <b>LH12</b> = large halogen, 6V, 12V - 12 watts, quartz sealed beam <b>LH20</b> = large halogen, 6V - 20 watts, quartz sealed beam <b>LD7</b> = 12V - 4 watts LED	<b>Blank</b> = factory white <b>BK</b> = black	<b>Blank</b> = 120/347Vac input <b>U277</b> = 277Vac input <b>U240</b> = 240Vac input <b>U220</b> = 220/50hz Vac input	<b>A</b> = ammeter <b>CT</b> = cabtire <b>D3</b> = time delay 15 min. <b>D6</b> = 6cct. fuse panel <b>IT</b> = AC terminal block <b>LB</b> = light activated test switch <b>LD</b> = lamp disconnect <b>OT</b> = output terminal block <b>R1</b> = remote test receiver* <b>R2</b> = remote test transmitter <b>TL</b> = twist lock plug <b>V</b> = voltmeter
<b>LDX12</b> = 12 volts  <b>EXAMPLE:</b> LDX12-100AD2RT9	<b>-36</b> = 36 watts [A]* <b>-72</b> = 72 watts [A]* <b>-100</b> = 100 watts [A]* <b>-144</b> = 144 watts [A]* <b>-200</b> = 200 watts [B]* <b>-250</b> = 250 watts [B]* <b>-360</b> = 360 watts [B]*						
<b>LDX24</b> = 24 volts  <b>EXAMPLE:</b> LDX24-144AD2RT9	<b>-144</b> = 144 watts [A]* <b>-200</b> = 200 watts [B]** <b>-288</b> = 288 watts [B]* <b>-350</b> = 350 watts [C]* <b>-432</b> = 432 watts [C]* <b>-550</b> = 550 watts [C]* <b>-720</b> = 720 watts [C]*	*Not all options are available with NEXUS® System. Please consult your sales representative for output power range.					

\*Remote test transmitter required.