

Project/Location: _____

Contractor: _____

Date: _____

Prepared by: _____

LDX-TE Series

NEMA-4X Classified

6 and 12 Volts Battery Units



Typical Specification

Supply and install a complete emergency lighting system as described herein and shown on the drawings. The Ready-Lite Smart Diagnostic Micro-controller board shall supply the rated load for a minimum of a 1/2 hour to 87.5% of the rated battery voltage. The unit shall be rated 120V or 347V, 60 Hz and be CSA listed. The unit shall have an output of _____ volts. The charger shall be fully computer tested and its charge voltage factory set to $\pm 1\%$ tolerance. Chargers with field-adjusted potentiometers are not acceptable. A pulse-type charger shall be employed to promote long battery life and reduce the potential for grid corrosion. The charger shall provide a continuous high charge to recharge the battery, when the battery is at full capacity, the charger will shut-off. Periodically the charger shall provide a pulse of energy to keep the battery topped off. The pulse charger shall be current limited and precisely regulated by a microcontroller circuit, which samples the battery in relation to its temperature, state of charge and input voltage fluctuations. The charger shall be current limited, temperature compensated, short-circuit proof and reverse polarity protected. The unit shall be furnished with an electronic lockout circuit, which will connect the battery when the AC circuit is activated, and an electronic brownout circuit, which will activate the emergency lights when utility power dips below 75% of nominal voltage. A low voltage battery protection circuit shall be provided and will disconnect the battery from the fused output circuit at the end of discharge. The unit shall self-test for 1 minute every 30 days, 10 minutes on the 6th month and 30 minutes every 12 months. The unit shall be capable of full recharge in compliance with CSA specifications. The unit shall be furnished with sealed dust tight relay, a test switch and diagnostic LED indicator lights to continuously monitor the status of the unit: Battery Failure, Battery Disconnected, Charger Failure, Lamp Failure, Service Alarm, AC "ON", Charger High Rate.

The unit shall be NEMA-4X and suited for water, oil and dust tight applications.

The unit shall be Ready-Lite Model: _____.

Features

- Fully gasketed fiberglass cabinet with clear polycarbonate cover
- Solid-state pulse-type charger – current-limited, temperature-compensated, short-circuit proof and reverse-polarity protected.
- Unit comes standard with electronic lockout and brownout circuits
- Sealed dust-proof transfer relay, test switch and LED indicator light(s)
- Long-life, maintenance-free sealed lead acid battery
- Choice of mini tungsten or mini halogen lamp heads (see Ordering Information for complete details)
- Standard 120/347Vac input voltage with line cord kit
- CSA C22.2 No. 141 certified



Wire Guards

460.0082-RL	Wall Mount
-------------	------------

Replacement Lamps

Model	Type	Voltage-Wattage
580.0013-RL	Quartz Bi-Pin	6V-8W
580.0014-RL		12V-8W
580.0011-RL		6V-12W
580.0015-RL		12V-12W

Dimensions

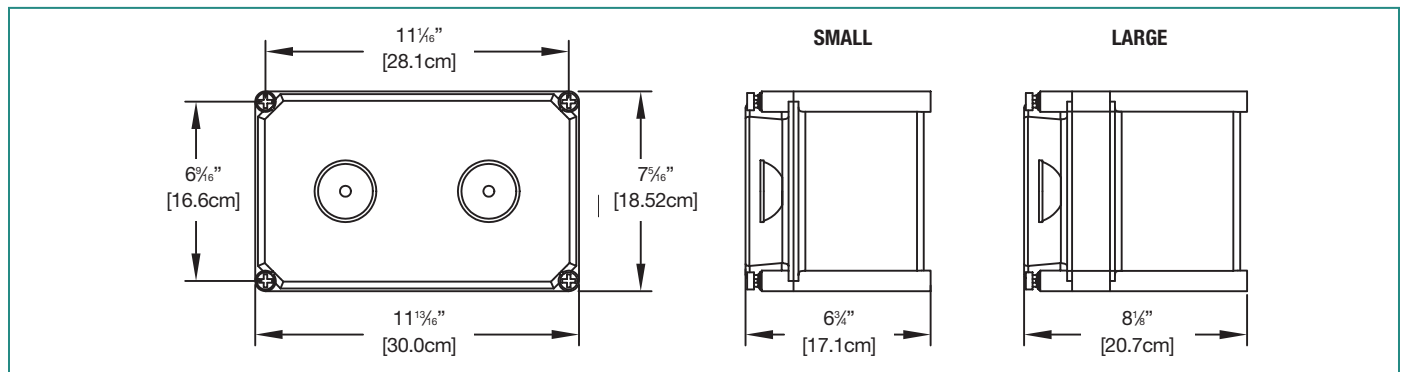

Pour commander

Series	Capacity	Housing	Special Options	Style/Wattage	AC Voltage	Options
LDX6 = 6 volts EXAMPLE: LDX6-36TEAD2	-36 = 36 watts -72 = 72 watts -108 = 108 watts	TE = NEMA 4X	Blank = standard AD = self-diagnostic	Blank = mini halogen, 6V, 12V - 8 watts, quartz bi-pin 12 = mini halogen, 6V, 12V - 12 watts, quartz bi-pin	Blank = 120Vac input U277 = 277Vac input U347 = 347Vac input	D3 = time delay 15 min. LD = lamp disconnect LB = light activated test switch TL = twist lock plug HTR = heater and thermostat
LDX12 = 12 volts EXAMPLE: LDX1272TEAD2	-36 = 36 watts -72 = 72 watts -144 = 144 watts					