

Project/Location:

Contractor:

Date:

Prepared by:

# Ultima™ Series Battery Unit



## Typical Specification

Supply and install the **Ready-Lite Ultima™ Series** of battery unit equipment. The unit construction shall include a housing and a front cover, high-impact thermoplastic moulded in white. No screws shall be necessary to hold the front cover to the housing. The unit shall be equipped with two emergency heads with adjustable swivels and MR-16 lamps of \_\_\_ V \_\_\_ W protected by snap-on shock-absorbent, clear polycarbonate covers. The unit shall be suitable for wall mount or as otherwise specified.

The unit equipment shall have a dual-voltage input of 120/347Vac and shall be equipped with a test switch and a green pilot light, located on the left side. The housing shall host the battery and the battery charger. The battery charger and other unit functions shall be driven by a micro-controller. All electronic circuitry shall be installed on a single printed circuit board.

When specified, the unit equipped with Self-diagnostic shall automatically self-test for one minute every 30 days, 10 minutes in the 6th month and 30 minutes annually. When a fault is detected, the bi-color pilot light shall turn from green to red and start flashing. A legend on a label next to the pilot light shall display the source of failure: battery, charger circuitry or lamp load.

The unit equipment shall be listed to the standard CSA 22.2 No.141.

The unit equipment shall be Ready-Lite model: \_\_\_\_\_.

## Dimensions

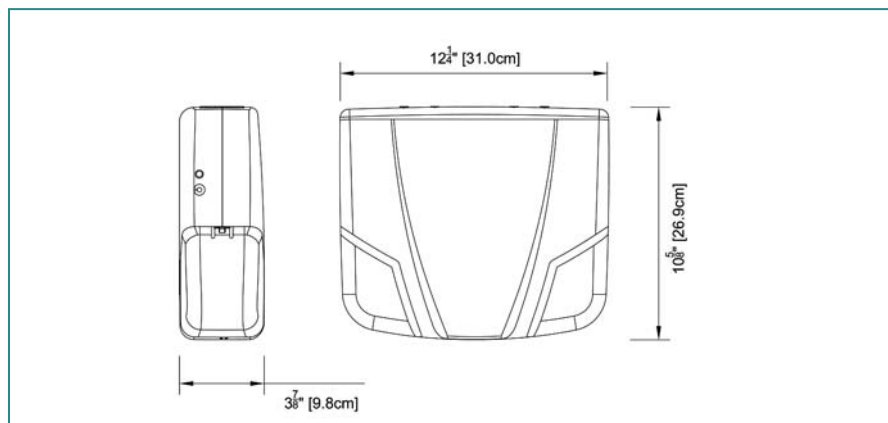

## Features

Designed with aesthetics, ease of installation and performance in mind

- Simple, compact and contemporary design
- Wall-mount or ceiling-mount installation
- Two-piece housing of injection-molded thermoplastic
- Two MR16 halogen lamps, shielded by clear polycarbonate covers
- Available with long lasting MR16 LED lamps
- Sealed, maintenance-free, Lead-Calcium or Nickel-Cadmium batteries
- Dual voltage input: 120/347 Vac.
- Up to 150W of total battery capacity
- Self-diagnostic (optional)
- NEXUS® interface (optional)
- Listed CSA 22.2 No.141



## Wire Guards

460.0114-R Wall Mount or flat ceiling mount

## Replacement Lamps

Model	Lamp Type	Voltage-Wattage
580.0079-RL	MR16	6V-10W
580.0080-RL	MR16	12V-12W
580.0064-RL	MR16	12V-20W
580.0093-RL	MR16 LED	12V-4W

## Power Consumption and Unit Rating

Model	AC Specs		Wattage Capacity				
			30 minutes	60 minutes	90 minutes	2 hours	4 hours
640	120 / 347Vac	0.25 / 0.09 A	40	23	16	12	-
672			72	42	30	24	12
1280			80	44	32	26	13
12120			120	70	50	40	20
12150			150	84	60	48	24

## Flat Ceiling Mount



## Ordering Information

Series	Capacity	Unit Type	Heads	Lamps	Colour	Voltage	Options
<b>ULT6</b> = 6 volts	<b>40</b> = 40 watts <b>72</b> = 72 watts	<b>Blank</b> = standard <b>AD</b> = self-diagnostics <b>ADN</b> = self-diagnostics non-audible <b>NEX</b> = NEXUS® system interface <b>NEXRF</b> = NEXUS® wireless system interface	<b>0</b> = no heads <b>2</b> = two heads	<b>RM6</b> = 6V - 6 watts MR16 <b>RM10</b> = 6V, 12V - 10 watts MR16 <b>RM12</b> = 12V - 12 watts MR16 <b>RM20</b> = 12V - 20 watts MR16 <b>LD7</b> = 12V - 4 watts, LED	<b>W</b> = factory white <b>B</b> = black	<b>Blank</b> = 120/347Vac <b>2</b> = 120/277Vac	<b>Blank</b> = no options <b>D3</b> = time delay 15 min <b>LC</b> = line cord (120V only) <b>CM</b> = ceiling mount
<b>ULT12</b> = 12 volts	<b>80</b> = 80 watts <b>120</b> = 120 watts <b>150</b> = 150 watts						

EXAMPLE: ULT6402RM6W